



Triolo

**SEWAGE PUMP
DP SERIES**

DP

The DP series offers a quick solution for drainage and sewage systems for a wide range of applications including construction, wastewater, mining, municipal and more. With a durable construction, the pump offers a long operating life with minimal maintenance. Featuring an effective motor cooling and protection, a higher level of reliability and durability.



PUMP POWER

Featuring a compact and versatile construction, with high durability and low power consumption, the DP series is a solution for a wide range of applications from residential to industrial grade operations.

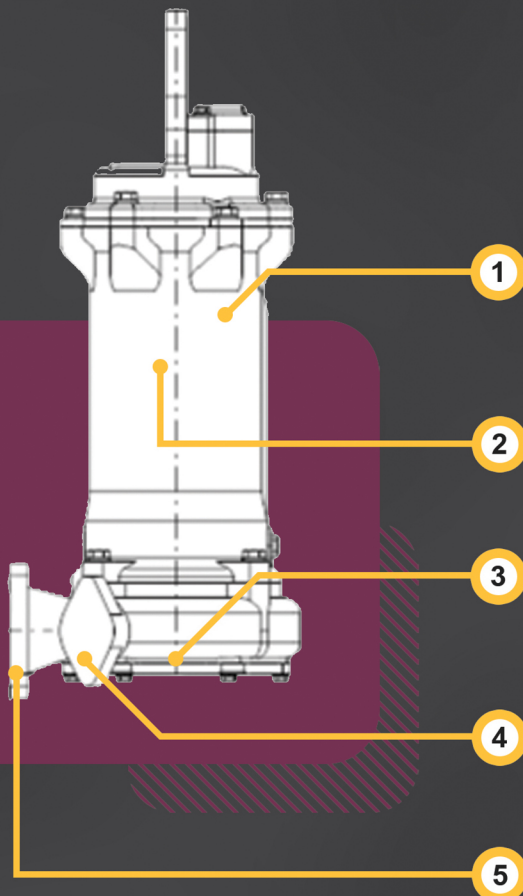

Teknologi

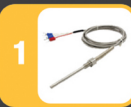

PROTECTION SENSORS+

DP series motors are equipped with sensors for monitoring the temperature and condition of the motor at any time, anticipating the need for faster inspections.



COMPACTIBILITY

Dengan desain yang smart, minimalis, dan ringan seri D sangat cocok untuk penggunaan mudah bagi semua aplikasi/sector.



EFFICIENT NON-CLOGGING

Memaksimalkan kemampuan single channel impeller, seri DP menggunakan sistem efisien dan anti-clogging, melindungi pompa dari ketersumbatan.

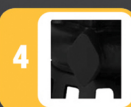

FLUSHING CHAMBER

Ruang impeller dapat dilakukan pembersihan untuk memperpanjang umur pompa melalui system flushing di samping chamber impeller.



QUICK DISCHARGE CONNECTION

Coupling antara pompa ke pipa fleksibel dengan QDC yang dapat dipasang untuk sambungan pipa atau hose dengan ukuran yang dapat disesuaikan.

PUMP PERFORMANCE

Applications

- Fire-fighting
- Distribusi & Boosting Air
- Kebutuhan Industri
- Pengairan Bandara
- Irigasi & Fertigasi
- Pasokan air

Technical Specifications

Capacity up to	L/s	27
Head up to	m	44
Power up to	kW	7,5

DP

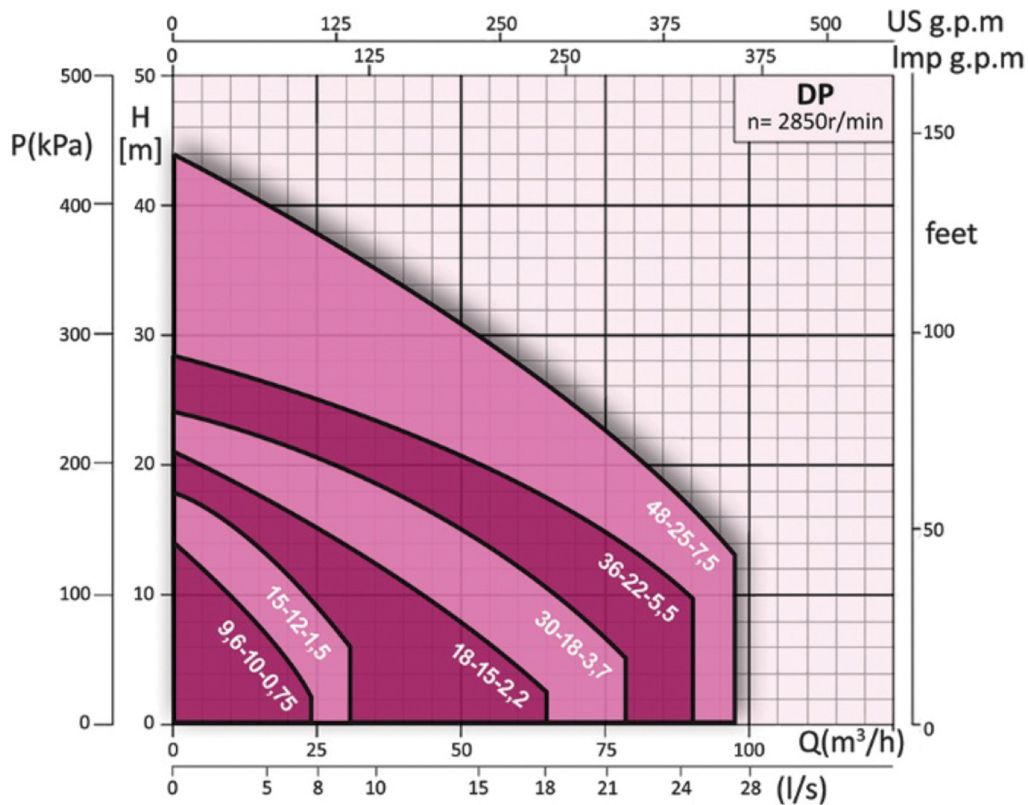

EXCELLENT
HEAVY DUTY
PUMPING



Triolo

Designed for **PERFORMANCE**



+62 31-9914-3626



contact@triolo.co.id



WWW.TRIOLO.CO.ID



Jalan Darmo Permai Mayjen Yono Suwoyo
III no.36, Surabaya, Indonesia 60216